



PRESSURE STEAMERS

PRESSURE STEAMERS

2 OR 3 OR 4 COMPARTMENTS

DIRECT STEAM, OPEN STAND

PEDESTAL BASE OR WALL MOUNTED

MODELS: 2 Compartments 3 Compartments 4 Compartments
 PDL-2 PDL-3 PDL-4
 PDW-2 PDW-3 PDW-4
Cleveland Standard Features

- 5 psi Operating Pressure in cooking compartments
- Mechanical interlock prevents unlatching door while compartment is pressurized
- Timers, one per compartment, are mechanical style with audible signal
- Thermostatic Trap vents cooking compartment automatically
- Steam Inlet Valves and Exhaust Valves interlocked for synchronous action
- 8 psi Compartment Safety Valve
- Capacity per compartment for eight, 12" x 20" x 2 1/2" deep Cafeteria Pans, or four, 18" x 26" Bun Pans
- Heavy Duty, free floating, cast aluminum compartment doors
- Compartment Door Hinges have adjustable hinge pins and self-lubricating bushings
- Door Gasket replaceable without tools
- Pressure Gauge for compartment Operating Pressure
- Compartment Slide Racks are removable without tools, for easy cleaning
- Type 430 Stainless Steel: external enclosure, Table Top and eight gauge plate cooking compartments
- Moisture Separator for incoming steam
- Pressure Reducing Valve for 12 to 50 psi steam supply pressure
- 6" Adjustable Legs with flanged feet

Options & Accessories

- Automatic Steam Inlet and Exhaust Operation (AT-2): includes 60 minute Automatic Timers and Manual Bypass
- Second Pressure Reducing Valve for 50 to 120 psi supply pressure (PRV)
- Special Compartment Slide Racks
- 12" x 20" Cafeteria Pans 1", 2 1/2", 4" or 6" deep
- Intermediate Pull-Out Shelf (POS)
- In-Wall Carrier, for wall mounted units only (IWC-PDW)

- ▲ Clean, non toxic, uncontaminated steam is required for all "Direct Steam" steamers

ITEM NUMBER _____

JOB NAME / NUMBER _____

**Short Form Specifications**

Shall be ____ Compartments, CLEVELAND, Pressure Steamer, Model PD- ____ - ____, for Direct Steam operation,; ____ volts, single phase. Each Cooking Compartment equipped with: 60 Minute Timer; Pressure Safety Valve; Heavy-duty, free floating Door with Safety Interlock; and synchronous operating Steam Inlet and Exhaust/Drain Valves. Compartments are mounted to a Low Cabinet type base or Wall Mounted. Includes a Pressure Reducing Valve and Moisture Separator.

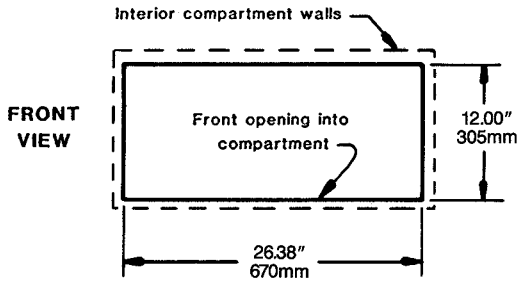

- Each compartment has capacity for:
 Eight, 12" x 20" x 2½" Cafeteria Pans or
 Six, 12" x 20" x 4" Cafeteria Pans or
 Four, 12" x 20" x 6" Cafeteria Pans or
 Four, 18" x 26" Bun Pans
- Many regional, state and local codes exist and it is the responsibility of the owner and installer to comply with those codes.
- Cleveland Range equipment is built to comply with applicable standards for manufacturers. Included among those approval agencies are: UL, ULC, NSF, and CSA.

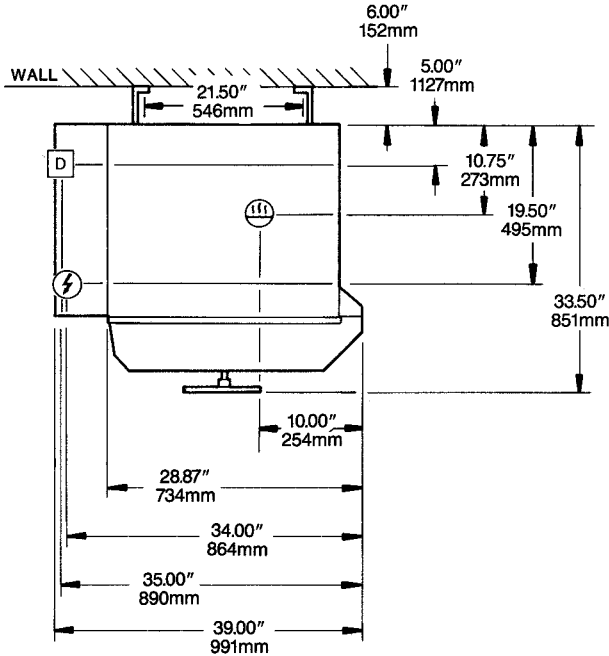

WATER QUALITY REQUIREMENT

The recommended minimum water quality standards whether untreated or pre-treated, based upon 10 hours of use per day, and a Daily Blowdown, are as follows:

TOTAL DISSOLVED SOLIDS	less than 60 parts per million
TOTAL ALKALINITY	less than 20 parts per million
SILICA	less than 13 parts per million
pH FACTOR	greater than 7.5
CHLORINE	less than 30 parts per million

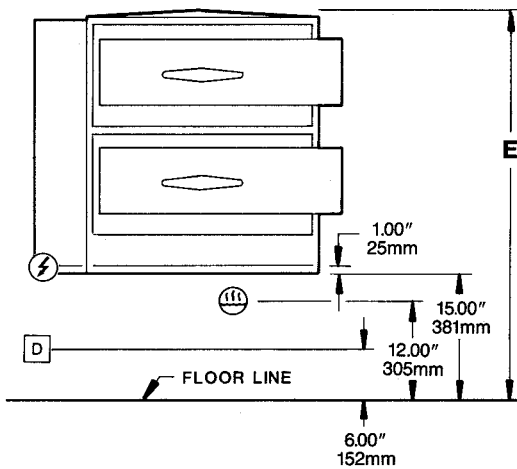

Consult a local water treatment specialist for an on site water analysis for recommendations concerning steam generator feed water treatment (if required), in order to remove or reduce harmful concentrations of minerals. The use of highly mineralized water will mean that more frequent servicing of the steam generator will be necessary. The fact that a water supply is potable is not proof that it will be suitable for the generator.

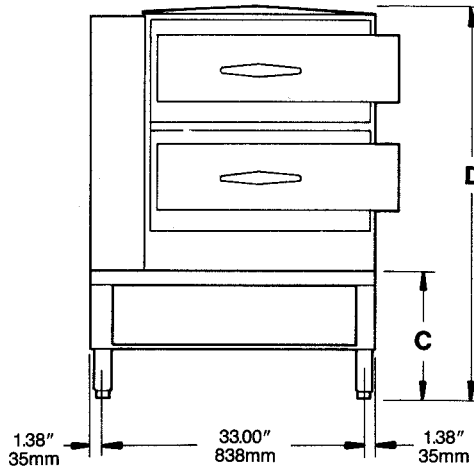

WALL MOUNTED



LOW-CABINET TYPE

STEAM 	ELECTRIC 	DRAINAGE 	CLEARANCE
Steam supply piping: • ¾" IPS minimum line. 12 to 45 psi required. • For pressures above 45 to 120 psi, an additional Pressure Reducing Valve must be specified.	115V-1 Phase Units with Auto Timers use 25 watts per compartment	1" IPS common drain. Do not connect other units to this drain. Do not use PVC pipe for drain.	Right - 3", Left - 3", Rear - 3" (12" on control side if adjoining wall or equipment is over 30" high for service access) Contact factory for variances to clearances.

		A	B	C	D	E
2 Compartments	IN	23.44	57.06	22.00	55.63	48.00
	mm	595	1449	559	1412	1219
3 Compartments	IN	19.44	63.06	18.00	61.63	59.00
	mm	494	1602	457	1565	1499
4 Compartments	IN	15.44	73.06	14.00	71.63	72.00
	mm	392	1856	356	1819	1829